

Garrard
automated
single-play
turntables

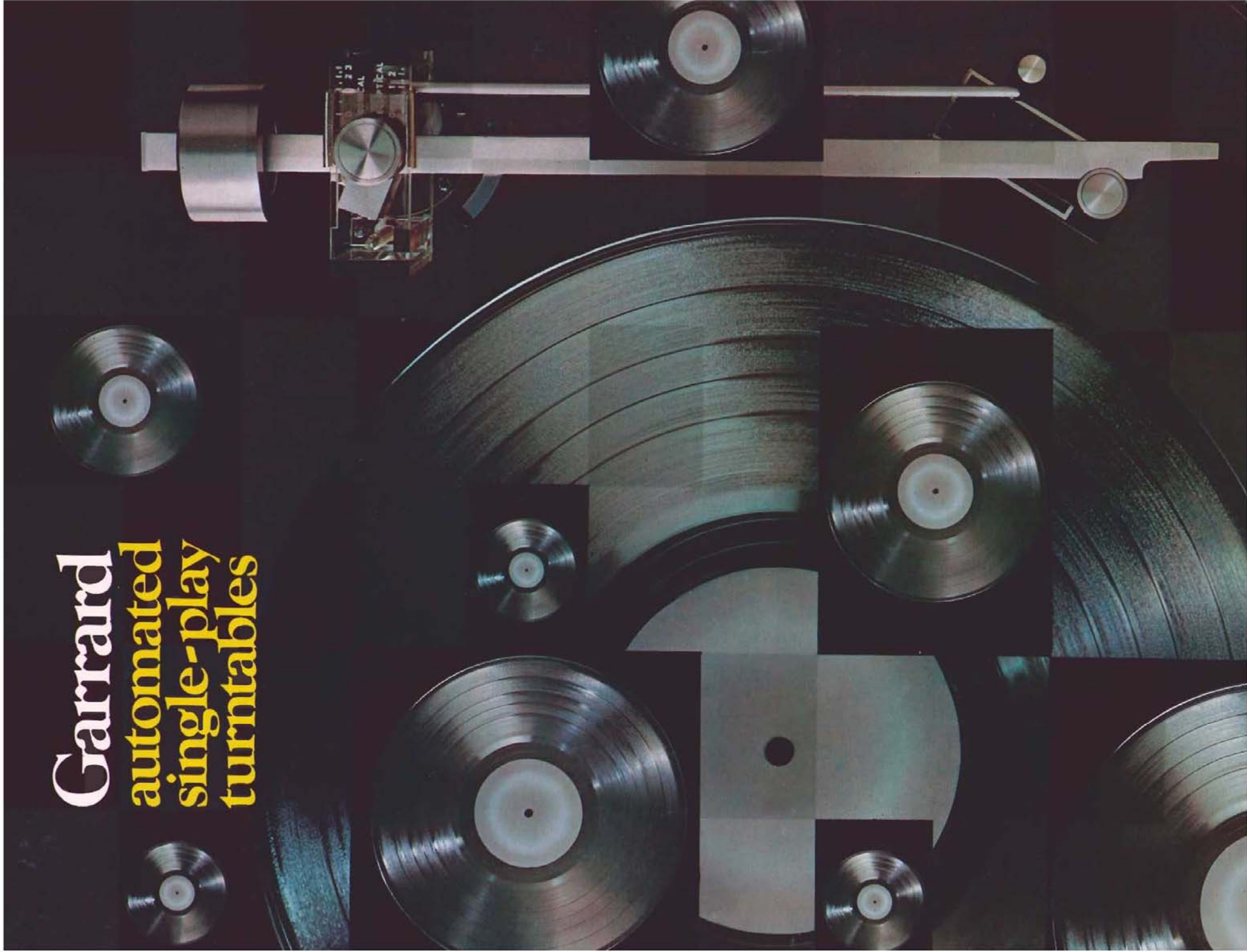



Garrard Zero 100SB

Rarely does a high fidelity component earn universal praise. But such is the case with the Zero 100SB.

Start with the Zero Tracking Error Tonearm. It enables the stylus to precisely follow the path of the original master cutting head. This means no tracking error, no distortion, no groove damage.

To prevent skating force, (the tendency of the stylus to be hurled against the inner wall of the record groove resulting in distortion and excessive wear), a remarkable anti-skating device is employed. On the prin-

ciple that like poles repel, ingeniously placed magnets provide mastery over skating force as well as adjustment for spherical or elliptical styli.

A heavy, 5 lb., die cast and dynamically balanced platter of zinc alloy prevents even minute fluctuations of speed. The platter is driven by a flexible belt which isolates the motor from the platter. The resulting rumble, wow and flutter levels are remarkably low. Rumble: -64dB. Wow: 0.06%. Flutter: 0.04%.

The motor itself is Garrard's famous Synchrono-Lab unit, combining the advantages of the power of a 4-pole induction motor with the constant speed of a synchronous type.

Also featured in the Zero 100SB are an automatic record counter (to tell you how many records have been tracked by the stylus), damped cueing

(in both directions) and precise adjustment of tracking force without the use of springs.

Given Garrard's long experience in *changer* engineering, it was only natural to combine the straightforward design of the single-play unit with the convenience of automation. The tonearm indexes at the beginning of the record, returns to the arm rest at the end, and shuts off the motor—all by itself.

The total result is a superb musical experience enjoyed in utmost confidence that the disc is being played with a precision and gentleness that assures long life for the record, the stylus and the turntable. There exists no better way of playing a record than on the Garrard Zero 100SB. \$209.95 including teak veneer base and hinged dust cover.



Garrard 86SB

The main difference between the 86SB and the Zero 100SB is the tonearm. The 86SB has an extruded aluminum arm with fixed offset, gravity-controlled stylus force adjustment (no springs), precision-loaded ball bearing pivots, lever- and-sliding-weight anti-skating control (adjustable for spherical or elliptical stylus) and ultra-lightweight perforated head. It is fully automatic, indexing at the beginning, returning to the arm rest and shutting off the motor at the end of play.

A glance at the comparative chart on the back cover will reveal that the 86SB specifications are virtually the same as those of the Zero 100SB—a fine recommendation indeed.

Like the Zero 100SB, the 86SB has earned enthusiastic reviews. High Fidelity Magazine: "... The rumble

is very low at -61dB ... while the wow and flutter are equally excellent ... These are, of course, the prime reasons for buying the 86SB".

As for the tonearm, CBS Labs reported: "... the arm is exceptionally fine ... the lab could measure no significant bass resonance ...". The review concluded: "In the most important respects ... the Garrard 86SB offers unusually fine performance plus automation at what must be reckoned a bargain price ... Fitted with a fine cartridge tracking in the range between 1 and 2 grams (and there are many), it can be expected to hold its own in sonic comparison with just about any other model."

There is little that can be added to such comments by the experts. \$159.95 including teak veneer base and hinged dust cover.

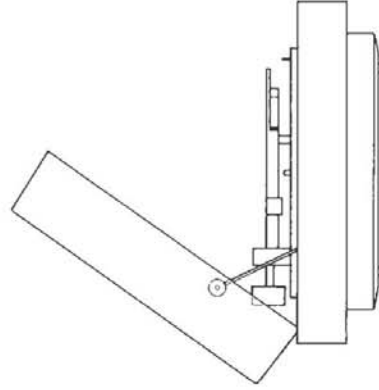

Base and dust cover for the Zero 100SB and 86SB.

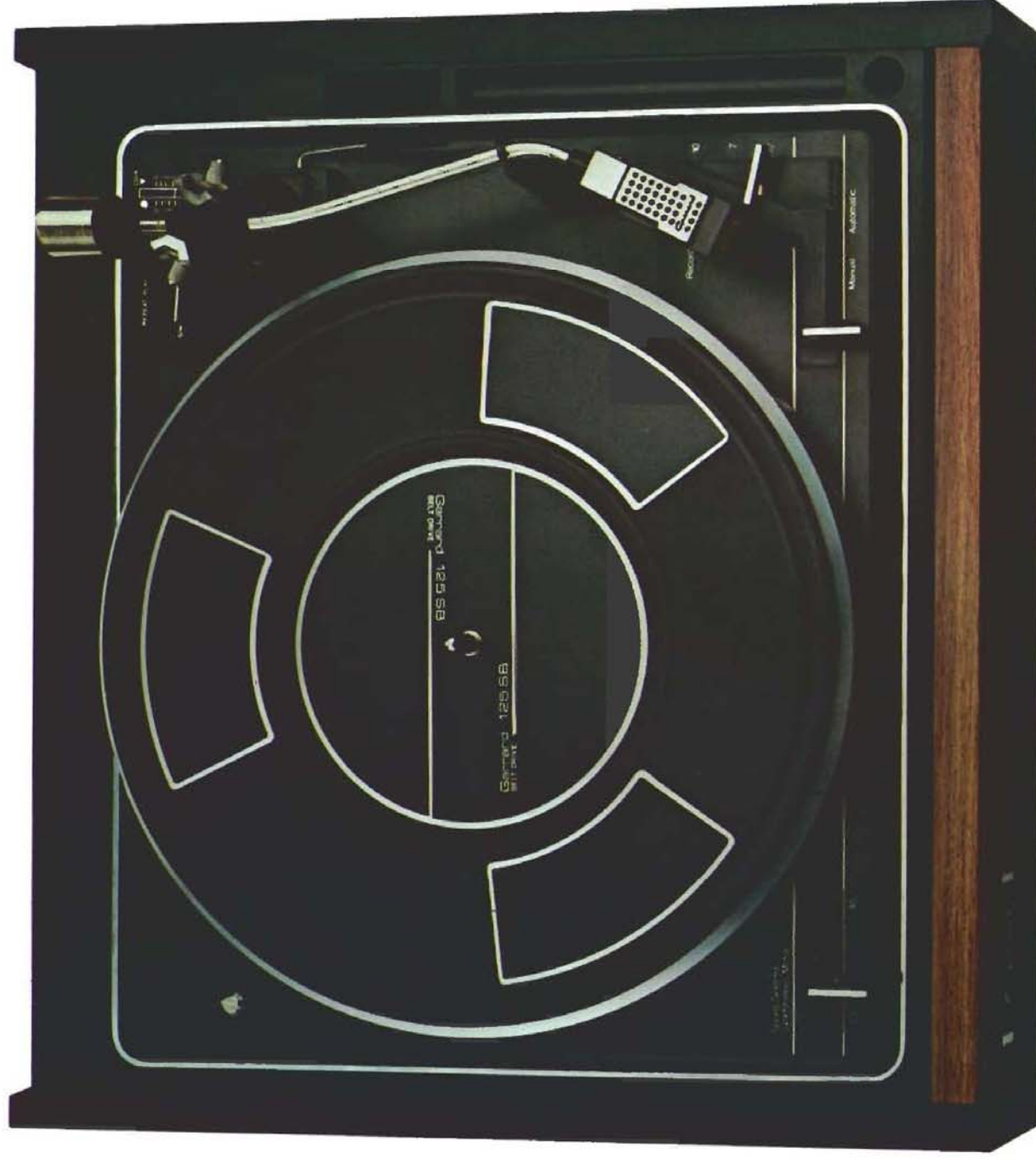

Garrard 125SB

This model is the newest member of the Garrard single-play turntable family. It was designed and constructed for music lovers who must resolve the conflict between fine reproduction of music and a modest budget. Consider it resolved.

The S-shaped tonearm of the 125SB is tubular with a lightweight aluminum head. Its basic characteristics result in low mass, low friction and excellent tracking.

The 125SB boasts precisely the same Synchrono-Lab (4-pole, synchronous) motor as in the Zero 100SB and the 86SB. The deep, aluminum platter is belt driven, isolating it from any conceivable motor vibrations. The 125SB, like all Garrard single-play turntables, is fully automatic, providing indexing, return to arm rest at the end of play and

motor shut-off. In addition, a Repeat Play control enables listeners to play a single recording automatically as many times as they desire.

The 125SB has a unique combination base and dust cover of Garrard's own design: The Unipivot. When the dust cover is raised, part of it actually slips into the base providing much greater flexibility in placing the turntable where space is a problem.

In every respect—Garrard's tradition of excellence and reliability, precision engineering and meticulous protection of the record—the 125SB is highly recommended to the first-time high fidelity buyer and to the more experienced listener with a limited budget. \$109.95 including Unipivot base and dust cover.

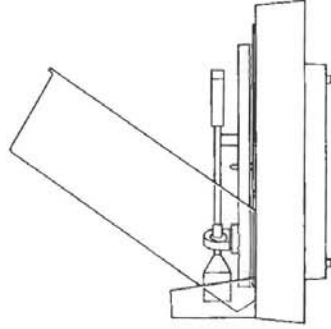

Integral Unipivot base and cover.

The Zero Tracking Error Tonearm

This Garrard invention expanded state-of-the-art. It eliminates tracking error, one of the major causes of distortion. How tracking error was eliminated in a tonearm is one of the most meaningful chapters in the history of audio engineering.

The idea is simple and straightforward. The offset head of a *conventional* tonearm cannot remain tangent to the record groove at all points on the record . . . so why not *hinge* the head and make its offset angle variable?

The execution of the idea required the creation of a hinged trapezoid (a kind of double arm). The brilliance of the engineering that went into this complex design is emphasized by the fact that both mass and friction have been kept as low as in the finest conventional arms, while completely eliminating tracking error.

That the project was worth the effort is apparent from the reviews which descended upon Garrard. Typical was the one from the prestigious Hirsch-Houck Labs, as described in Julian D. Hirsch's "Product Test Reports" in Popular Electronics.

... tracking error was unmeasurably low (under 0.5 degree) over the entire record surface. The stylus force indications were very accurate, with less than .05 gram error at 1 and 2 gram settings and only 0.1 at 3 grams.

This test, incidentally, established that the Zero 100SB arm, in spite of its multiple pivots, had negligible friction. As we see it, any cartridge made today can be operated in this arm at the lowest tracking force consistent with the design of the cartridge, without encountering difficulties of excessive arm friction.

The anti-skating calibration was correct for equal playback distortion in both channels (a very unusual occurrence among the many arms we have tested).

It boasts high performance in its basic characteristics at a price that matches or betters other record players of comparable quality. For example, only a few of the most expensive direct-drive turntables we have tested have shown lower rumble than the Zero 100SB.

... we found the Garrard Zero 100SB to be one of the smoothest, easiest-to-use record players we have seen. All its basic operating controls and their functions behaved exactly as intended, with none of the "bugs" that so often afflict mechanical systems. For example, when the cartridge is installed and the arm balanced according to instructions, the unit is actually set up correctly without additional adjustments with a stylus gauge and tracking error protractor to achieve optimum performance capability.

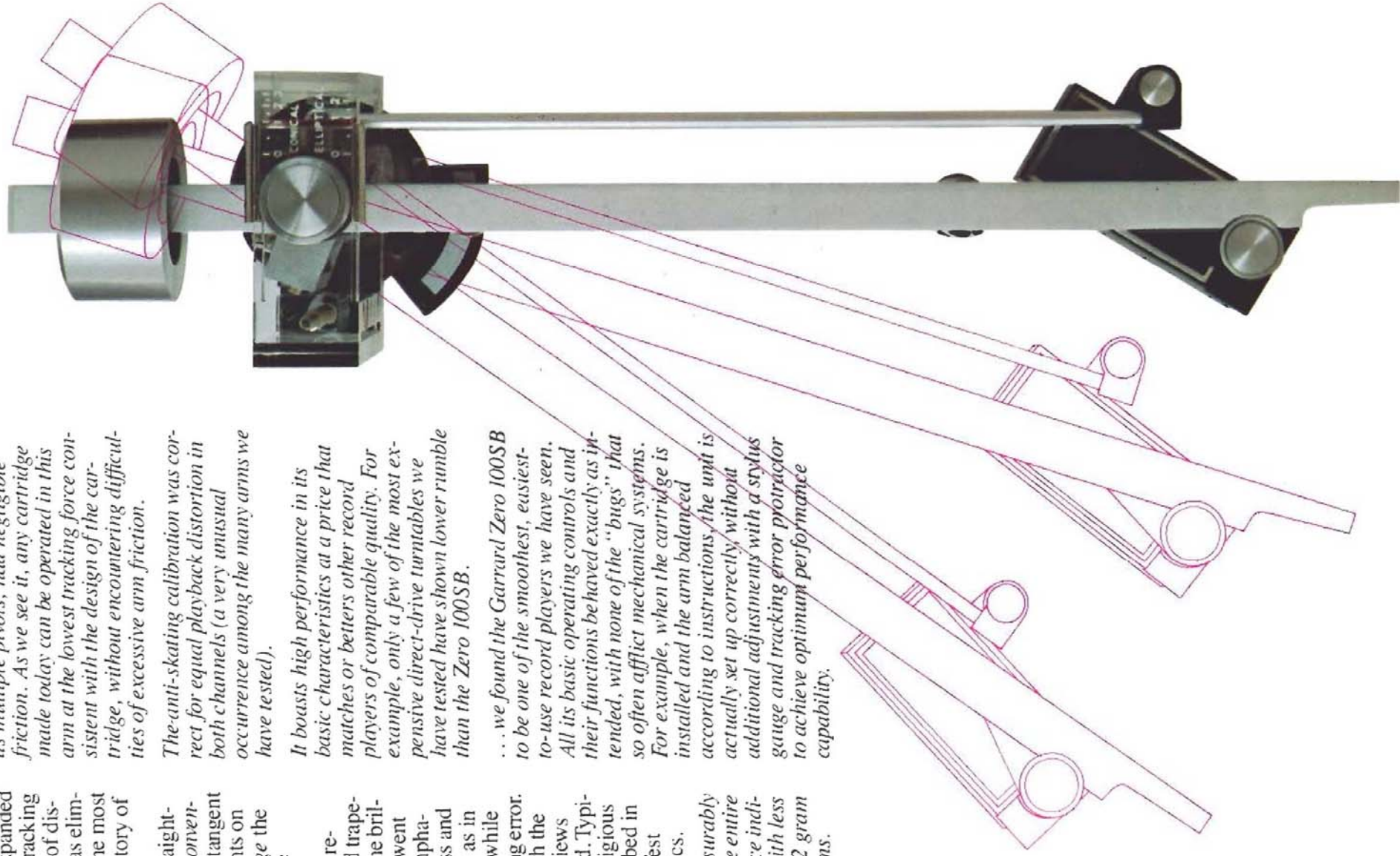

Model	Zero 100SB	86SB	125SB
Platter	11½ Die-cast zinc alloy, dynamically balanced	11½ Die-cast zinc alloy, dynamically balanced	11 Deep aluminum
Drive	Synchro-Lab 33⅓, 45 Flexible belt	Synchro-Lab 33⅓, 45 Flexible belt	Synchro-Lab 33⅓, 45 Flexible belt
Performance	-64 dB 0.06% 0.04%	-64 dB 0.06% 0.04%	-60 dB 0.08% 0.05%
Tonearm	Variable offset (zero tracking) Adjustable counterweight Precision-loaded ball bearings Sliding weight Magnetic, with spherical/elliptical calibration Viscous-damped for both lowering and lifting	Low mass Fixed offset Adjustable counterweight Precision-loaded ball bearings Sliding weight Sliding weight, with spherical/elliptical calibration Viscous-damped for both lowering and lifting	Low mass 'S' tubular Adjustable counterweight Combination ball bearings/needlepoint Adjustable counterweight Sliding weight, with CD-4/elliptical calibration Viscous-damped
Dimensions	With base and dust cover: 17⅞W x 15¾D x 7H	With base and dust cover: 17⅞W x 15¾D x 7H	With base and dust cover: 16½W x 15D x 8½H
Weight	25	25	14
Accessories	Integral (included) Integral (included) Optional	Integral (included) Integral (included) Optional	Unipivot BDC5 (included) Optional
All Garrard turntables have low capacitance tonearm leads and audio cables for optimum CD-4 performance			